

Coherent Frequencies, Consciousness and the Laws of Life

Cyril W. Smith

Retired from University of Salford, England

36 Westminster Road, Ellesmere Park, Eccles, Manchester M30 9EA, England.

cyril.smith@which.net

Abstract

This paper investigates frequency related aspects of coherence in water. The problem is that if living systems have a computing function how is it implemented? The language of communication in living systems is coherent frequencies. Work reported in CASYS '01, '05 & '07 showed that arithmetical operations could be performed on frequency imprinted aliquots of water and the basic reversible logic gates could be implemented. Memory for coherent frequencies in living systems involves water and H-bonding chemicals. The frequency information is in the A-field and this can be instrumented through the electric field $E = -dA/dt$. Endogenous frequencies can be altered in anticipation by consciousness and intention. Unfortunately there is no novelty, Nature has got in there first.

Keywords: Frequencies, Coherence, Water, Living Systems, Conscious Activity.

1 Introduction

Water is essential to Life and its Laws. The language of communication in water and within and between living systems is coherent frequencies. Fröhlich first introduced the physics of coherent frequencies in respect of biological systems and this is summarised in his two "Green Books". Del Giudice and Preparata showed that domains of coherence are a fundamental property of water. The writer has summarised this work (Smith, 2008).

One consequence of coherence is that frequency becomes a fractal-like quantity with no absolute value thus linking the chemical to the technological to the biological frequency bands. The limit to the possible degree of this coherence is the statistical fluctuations in the number of water molecules in a phase coherent state within a coherence domain and this is consistent with experiment.

In CASYS'01, the writer (Smith, 2001) showed that frequency imprints in water (RAM) could be subjected to all the basic arithmetical operations and in CASYS'05 that all the basic reversible logic gates could be devised similarly and so in principle, any reversible Boolean function could be computed in any aqueous system and be clocked by pulses as small as nerve impulses (Smith, 2005).

In CASYS'07, the writer (Smith, 2007) examined interactions between coherent frequencies and chemical structures as a possible way of proceeding from a dynamic to

a permanent memory. It was shown that water imprinted with the patterns of frequencies copied from mono-nucleotides could be modified to pass through the frequency patterns of DNA and RNA to the frequency pattern of the amino acid which was coded and this only using water and a specifically determined frequency. When the same procedure was carried out including traces of the chemical mononucleotides, the same frequency patterns were obtained. However, these would not erase in a mu-metal box so, it is possible that a chemical reaction had been catalysed by frequency structured water implying that frequency imprinted water can act like an enzyme.

Living cells can respond to a single quantum of magnetic flux linking the cell and thus have the Josephson effect available. They are sensitive to the magnetic vector potential which affects the phase of wave functions. The endogenous frequencies in living systems must be 'eigen' states of these wave functions. Living systems can show chaotic behaviour. The writer has pointed out that there may a chaotic state between the stable states of health and disease and that because of the nature of chaos, it is not possible to do double-blind trails on systems in such a chaotic state (Smith, 2009a).

The effects of frequency in biocommunication must eventually be limited at the quantum level through integer related quantum transitions between chemical states. Water, H-bonded to chemicals gives characteristic frequency patterns which living systems can recognise. This extends to the level of isotopes through the work of Partheil who found that acoustic mode frequencies could be related to atomic weights. The Rydberg Constant with the fractal-like ratios links frequencies and atomic mass. Therefore the ability to respond to coherent frequencies gives living systems the capability of identifying atomic isotopes.

Rowlands has described a form of expression for the 'Dirac Equation' which contains purely physical information so that mathematics becomes an intrinsic part of physical structure furthermore, the equation contains three terms which separately express the "energy", "momentum" and "mass" in the physical system. This equation can also be expressed in terms of *three frequencies*.

Marcer and Schempp have shown the quantum coherence and phase conjugation conditions necessary for a holographic memory system. This is the only memory system which satisfies a living system's need for an image of the actual location of the object in space and time. While there seems to be a continuum of frequencies available for constructing such a system, only two phases - Yin and Yang have been encountered so far.

2 Techniques for Performing Arithmetical Operations on Frequency Imprints in Water

The object here was to perform arithmetical operations on frequencies imprinted into water to demonstrate that this could be available for living systems to alter their frequency patterns. The spatial relation of the various components is shown in Figure 1. The particular arithmetical operation on the frequencies is specified through the sequence of binary stimuli shown. The pulse generator can be an appropriate electronic pulse generating circuit but most importantly the process will function at the level of a

train of nerve impulses. The decay time constant of the pulses should be greater than 5 microseconds and pulse separations should be less than 3 seconds. With the polarity positive, a '1' is generated, with it negative a '0' is generated. These binary pulses are conducted to the bases of the beakers by single insulated wires, implying that it is frequency coherence which is propagating. If the '1' and '0' pulses are interchanged, the imprint is in the opposite phase (here, '1' indicates biologically stimulatory and '0' indicates biologically depressive). The addition of a depressive imprint is equivalent to the addition of a negative number, that is to a subtraction.

The above binary sequences are not unique and certain keying combinations on calculators and ASCII code combinations on computers may approximate to the above binary sequences. Leakage fields from such instruments may affect these operations in living systems. Other binary sequences can be devised to effect other operations on frequencies e.g. raising to a power. There is an interaction with the magnetic vector potential component of the geomagnetic field and the greatest sensitivity is obtained with the orientation shown in Figure 1.

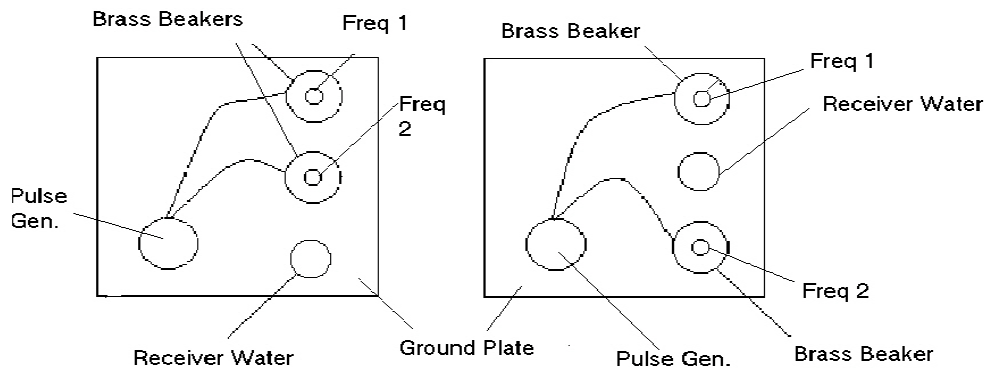

Addition 1001001 1111111

Multiplication 1001001 1111111

Subtraction 1000001 1111111

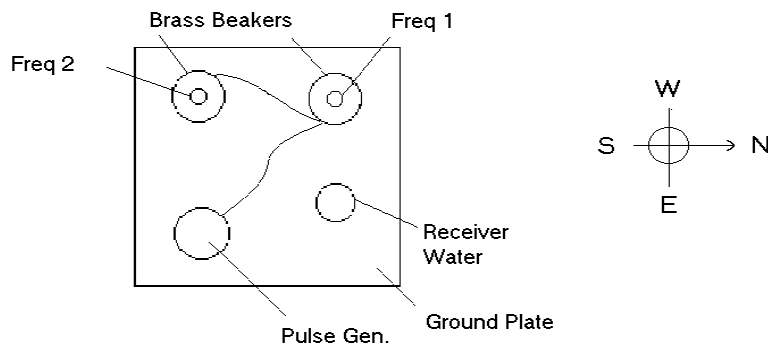

Division 1000001 1111111

Figure 1. Arithmetical Operations on Frequencies in Water.

3 Logic Gates in Water

(Figures and Tables 3.1-3.3 are reproduced from Smith, 2005)

The inputs and outputs for these gates were in water contained in glass tubes approximately 15 mm diameter and 100 mm length (BD Vacutainer - 10 ml) each containing about 5 ml of boiled, filtered, erased water. These were placed as shown in the following diagrams so as to touch 30 ml glass jars with metal caps also about half-full with the same water.

For these experiments, a frequency of 1 kHz was imprinted into the tubes indicated with un-primed letters in the phases shown in the Tables. The primed-letter tubes contained only the above water. The gate operation or 'potentiation' was 'clocked' by a train of 7-unidirectional voltage pulses produced from a 1.5 Volt battery using the mechanical contact indicated in the Figures. The water in these jars did not acquire any imprint. They seemed to be necessary to couple the input and output tubes in the appropriate spatial arrangement for their wave functions to overlap. Their positions were found as the result of trial-and-error. The non-primed tubes might contain chemicals for their frequency signatures to be processed.

3.1 N-Gate

If the input tube A is imprinted with a frequency in the stimulatory phase (a 1-state) and the other tubes carry no imprint, then after applying the 7-unidirectional pulses, tube A' carries a copy of the imprint in tube A while tube B' carries an imprint of the same frequency but in the 0-state, and conversely as shown in Table 3.1.

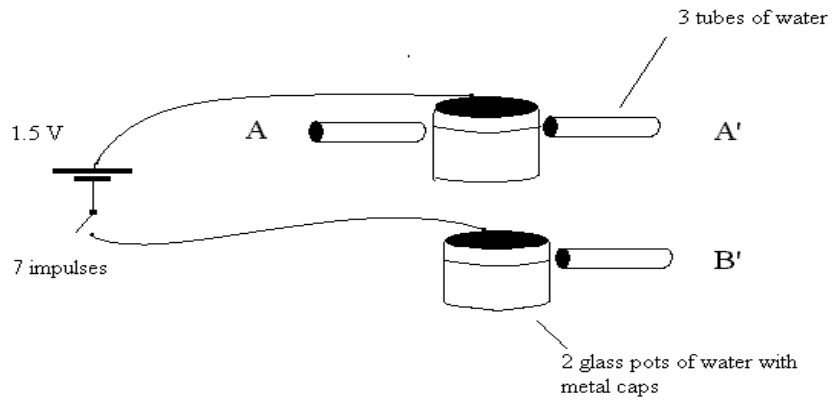

Figure 3.1: N-Gate

Table 3.1: N-Gate

A		A'	B'
Input			Output
0		0	1
1		1	0

3.2 CN-Gate

For this gate as shown in Figure 3.2, the observed states of the output (primed) for the given input states (un-primed) were appropriate for the CN-gate and as listed in Table 3.2.

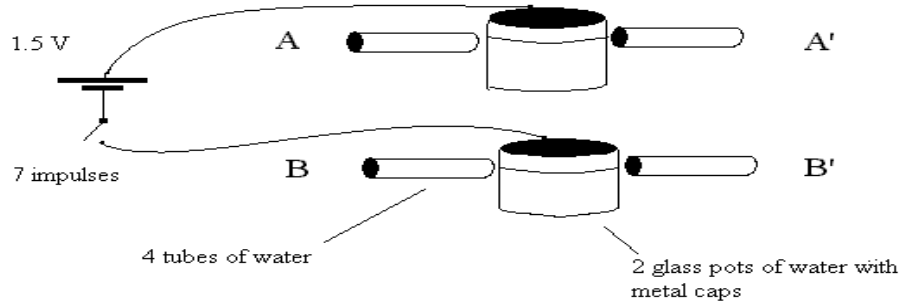

Figure 3.2: CN Gate

Table 3.2: CN-Gate

A	B	A'	B'
Input		Output	
0	0	0	0
0	1	0	1
1	0	1	1
1	1	1	0

3.3 CCN-Gate

For this gate an additional jar and two additional tubes were required as shown in the Figure 3 below; the observed states of the output (primed letters) for the given input states were as appropriate for the CCN-gate and are listed in Table 3.3.

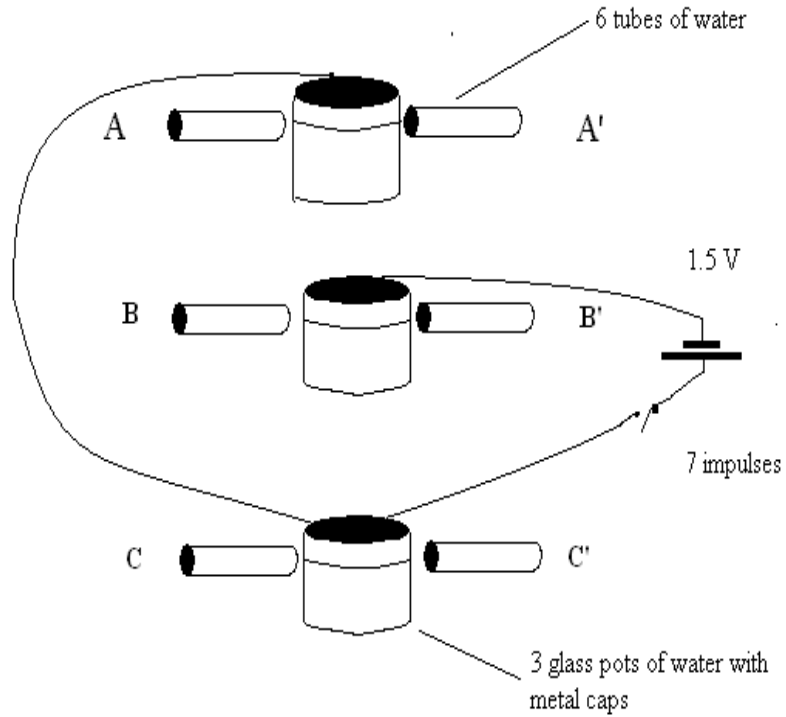

Figure 3.3: CNN-Gate

Table 3.3: CNN-Gate

A	B	C	A'	B'	C'
Input			Output		
0	0	0	0	0	0
0	0	1	0	0	1
0	1	0	0	1	0
0	1	1	0	1	1
1	0	0	1	0	0
1	1	0	1	1	1
1	1	1	1	1	0

4 Measuring Frequency Imprints

4.1 Frequency Memory

A water imprint is erased if the geomagnetic field is reduced below a critical value of about 375 nT. If erasure occurs when thermal energy exceeds magnetic energy, this

would occur in a spherical domain of phase coherence 52.92 μm diameter at ambient temperature. We showed in 1983 (Jafary-Asl et al., 1983) that living systems can respond to magnetic resonance (NMR) conditions, even at geomagnetic field strengths. Later, this suggested that a frequency might be retained in water if proton precession becomes coherently synchronised to an applied frequency and the coherent protons generate their own internal magnetic field such as to satisfy proton NMR conditions. Such a process should be stable unless the domain is thermally broken up by removing the stabilising geomagnetic field.

The proton NMR condition gives the precession frequency $\nu = \gamma B/2\pi$ where γ is the gyromagnetic ratio $2.675 \times 10^8 \text{ rad T}^{-1} \text{ s}^{-1}$, B is the magnetic field and ν is in Hz. The magnetic field B at the centre of a magnetic dipole from a rotating charge is:

$$B = \mu_0 n e v / 2a$$

where μ_0 is the permeability of free space, n is the number of charges e involved, v is frequency (Hz) and a is the radius of the orbit. Whence, the number of charges n required is independent of frequency and only depends on the size of the coherence domain which can be determined experimentally as described above.:

$$n = 4\pi a / \mu_0 e \gamma$$

The number of proton charges required to generate a magnetic field to satisfy NMR conditions is $n = 6.29 \times 10^{12}$. With two protons available for coherent synchronisation from each water molecule, 5.52×10^{15} protons should be available for taking up frequency imprints and enough protons to imprint 982 distinct frequencies. It was found that water at pH 5 would accept 935 frequency imprints, whereas an aliquot at pH 9 it would only accept 77. The pH of water expresses the availability of protons and as more frequencies are imprinted, the pH increases (Smith, 2007). On erasing the imprints, the pH returns to the original value.

The fractional bandwidth of the resonance of a frequency ν imprinted into water is about 4.6×10^{-6} from at least 10 MHz to 1 Hz. If the Heisenberg Uncertainty Principle is applied to such a system of lifetime t and there is a sufficient average number of particles $\langle n \rangle$ for the classical concept of phase to be meaningful, then:

$$\Delta n \cdot (h\nu) \cdot \Delta t \geq h/2\pi \quad \text{or} \quad \Delta n \cdot \nu \cdot \Delta t \geq 1/2\pi$$

If the system involves random events in a continuum of time, a Poisson Distribution is applicable and then:

$$\Delta n = \sqrt{\langle n \rangle}.$$

The spectral line width $\Delta\nu$ will be the reciprocal of the coherence time Δt so, for random particle fluctuations:

$$\Delta v / v \leq 2\pi / \sqrt{n}$$

Taking $\Delta v / v = 4.6 \times 10^{-6}$, the number of particles involved $n = 1.9 \times 10^{12}$. The protons involved in water memory are attached to water molecules so assuming that the fluctuation of one water molecule involves three effective protons (two bonded protons and two H-bonded ones) $n = \frac{1}{3} (6.29 \times 10^{12}) = 2.1 \times 10^{12}$ which is well within the present degree of experimental accuracy.

4.2 Frequency Detection and Measurement

Since the above memory mechanism involves moving charges, there will be a magnetic vector potential (A-field) component in the direction of motion. Since the currents involve charges precessing at the stored frequency there will be an alternating A-field at this frequency. Since $dA/dt = -E$, the A-field will generate an electric field proportional to the angular frequency ω .

A toroidal coil generates an A-field along its axis so, it was assumed that a wire placed axially would experience this E-field and acquire an electric potential proportional to the coherence length in the A-field. Accordingly, a 50mm length of copper wire was inserted into the input (BNC) connector of a low-noise amplifier (Brookdeal Electronics Ltd. LA350). A toroidal coil was placed with the wire along its axis.

The first experiment used an air-cored toroid for which the A-field could be calculated from the dimensions and winding details and the current. The voltage generated at the amplifier input was measured over a range of frequencies as shown in Figure 4.1. The resulting electric field calculated and the voltages for a toroid of length 10 mm is shown as 'Theory' in Figure 4.1. The ratio of the measured voltage to the electric field gave the effective coherence length as 6.9 ± 2.1 mm.

This experiment was repeated using a toroidal coil wound on a ferrite ring and the A-fields calculated as before. Measurement of the inductance gave the relative permeability as 5.2. The ferrite seems to have increased the measured voltage by a factor equal to its relative permeability. The coherence length became 67 ± 27 mm for a toroid of length 10mm.

Since an amplifier could measure the voltages so induced from A-fields, a glass tube of water was imprinted with the set of frequencies corresponding to the filter settings available in the amplifier. One end of the 50mm copper wire was connected to the amplifier input BNC, the other was inserted into this water. The frequencies measured are shown in Figure 4.2. Clearly a very respectable signal almost at millivolt level is available for measurement and analysis. The broad peak around 500 Hz may be a Maxwell-Wagner dispersion arising from the mix of coherent and incoherent water.

In view of the enhancement of the signal in Figure 4.1 when using a ferrite cored toroid, various ways of enhancing the signal coupled from the water into the amplifier were tried. These are summarised in Table 4.1. The best enhancement is plotted in Figure 4.2 where the glass tube of imprinted water was placed inside a brass beaker of a type already used in electroacupuncture.

Table 4.1 Enhancement of Signal Measured from Frequency Imprinted Water

Method	Enhancement	Comments
Single wire inserted into glass tube	1.0	The original method.
Glass tube placed in ferrite ring	1.5	Attempt to further stimulate with frequency applied to toroidal coil gave no effect.
Glass tube placed in a Caduceus coil	1.8	A non-inductive double winding.
Glass tube rested on a pancake coil.	2.3	The pancake coil couples to parallel E- and B- fields.
Water in a 200 mm plastic tube with and without 10 ferrite beads.	4.3	Different geometry.
Glass tube in electroacupuncture brass beaker and connected using socket in beaker.	5.7	Arrangement optimised for electroacupuncture.

5 Discussion

The human body's endogenous coherent frequencies can be altered in anticipation by application of consciousness and intention. The Laws of Life used by Nature must involve the application coherent frequencies. This seems to be quite general. All the chemicals involved in life which can H-bond to water have characteristic frequency signatures as with atomic isotopes. Humans have acupuncture meridians with characteristic frequencies which are probably formed when cells in an early stage of development become synchronous and this coherence persists as the organism develops into organs connected to sensitive points on the periphery. Even plants have an acupuncture meridian (Smith, 2009b).

Stressing an acupuncture meridian spreads its endogenous frequency into the whole body field. Homoeopathic potencies contain patterns of frequencies which can be modified by dilution and succussion. If the intention is to imprint nothing, nothing will be imprinted. Frequencies can become imprinted into measurement apparatus causing spurious results. Measurement procedures can be affected if the surrounding ambient air becoming potentised. It is then no longer possible to distinguish between specimens.

For 50 healthy subjects, the mean Heart meridian was 7.802 ± 0.002 Hz (i.e. ± 256 ppm). With this precision, it must be a reference frequency within the body. Because it has fractal-like connections it will be stabilised by resonances in the far-infra-red rotational spectrum of water.

The 7.8 Hz of the heart meridian enables the body to detect changes in the natural Schuman band radiation from the ionosphere. The Nerve Degeneration meridian which

describes that status of the entire autonomic nervous system could detect variations in 'sferics radiation.

An organism can alter frequencies according to metabolic needs, environmental factors, and by conscious intention. A healer can imprint water with a continuum of therapeutic frequencies and by intention can move the frequency of the Pericardium meridian (used in healing) close to that of the Heart meridian (a healing frequency). Imprinting water from the Heart Chakra not only imprints the 7.8 Hz as an electrical resonance but it also imprints 7.8 Hz as a resonance which can only be stimulated acoustically. The electrical

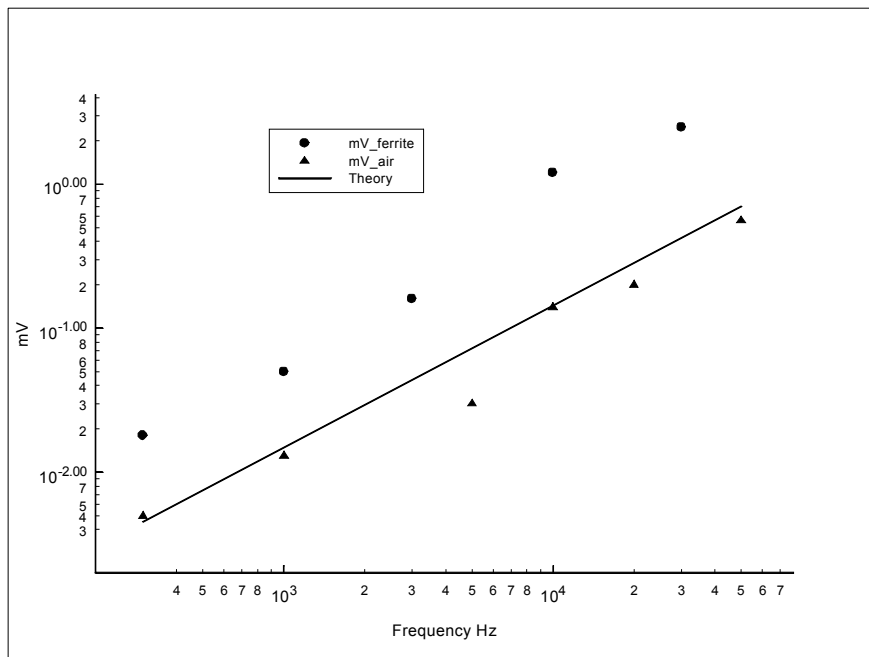

Figure 4.1 Induced Voltages Measured for a Toroid Field Coupled to an Amplifier

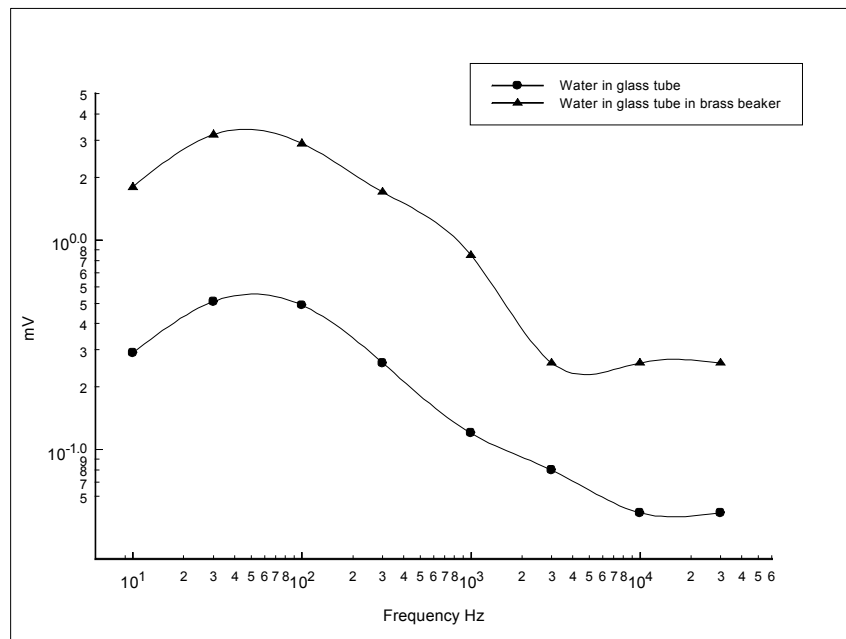

Figure 4.2 Voltages Measured from Frequency Imprints in Water

resonance can be erased by placing the imprint in a mu-metal box. Erasure of the acoustic resonance requires exposure to the 1.42 GHz (the molecular hydrogen frequency).

Thus, natural phenomena could have interacted with life through its laws as it evolved and living systems been conscious of them in subtle ways

Tiller and co-workers have explored the modification of space by intention imprinted electronic devices. The fourth volume (Tiller, 2007) refers to earlier work. Jahn and Dunn (2004) have considered anomalous consciousness-related physical phenomena.

There is no novelty to report in this paper, Nature has got in there first!

References

- Jafary-Asl AH, Solanki SN, Aarholt E, Smith CW (1983) *Dielectric measurements on live biological materials under magnetic resonance conditions*. J. Biol. Phys. **11**:15-22.
- Jahn RG and Dunne B (2004) *Sensors, Filters, and the Source of Reality*, J. of Sci. Explor. **18(4)**:547-570.
- Smith C.W. (2001) *Learning from Water, a Possible Quantum Computing Medium*, 5th. International Conference on "Computing Anticipatory Systems", HEC Liège, Belgium, 13-18 August 2001. CASYS'01 Abstracts - Symposium 10, p.19. *Intl. J. of Computing Anticipatory Systems* **13**:406-420 (2002).
- Smith CW. (2005) *Watergates – Logic Operations in Water*, 7th. International Conference on "Computing Anticipatory Systems", HEC Liège, Belgium, 8 - 13 August

In: Dubois DM (Ed.), Partial Proceedings of the Ninth International Conference CASYS'09 on Computing Anticipatory Systems, Liège, Belgium, August 3-8, 2009, Evolution of Living Systems and Biophysics, Risk Management, Optimization, and Control; 7th BCSCMsG International Symposium. Volume 25: 203-214. Abstract: CASYS'09 Symposium 10 p.17

2005. CASYS'05 Abstracts - Symposium 10, p. 9. *Intl. J. of Computing Anticipatory Systems* **19**:323-331 (2006).

Smith CW. (2007) *Water – Nanoscale to Microscale*. 8th. Intl. Conf. on Computing Anticipatory Systems, HEC-ULg, Liège, Belgium, 6-11 August 2007. Abstract: CASYS'07 Symposium 6 p. 23.

Smith CW (2008) *Fröhlich's Interpretation of Biology through Theoretical Physics*. In: Hyland GJ and Rowlands P (Eds.) Herbert Fröhlich FRS: A physicist ahead of his time. Liverpool: University of Liverpool, 2nd edition, pp 107-154.

Smith CW (2009a) *Can Homeopathy Ameliorate Ongoing Sickness?* The Journal of Alternative and Complementary Medicine (May 2009), Vol. 15, No. 5: 465-467.

Smith CW (2009b) *Plants may be slow but they are not stupid!* www.hpathy.com (April 2009).

Tiller WA (2007) *Psychoenergetic Science: A Second Copernican Revolution*. Walnut Creek CA: Pavior.